

Plain & Shoulder Pattern

Thumb Screws

Thumb & Wing Screws

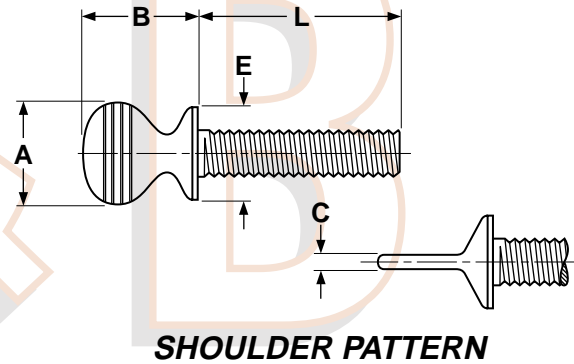
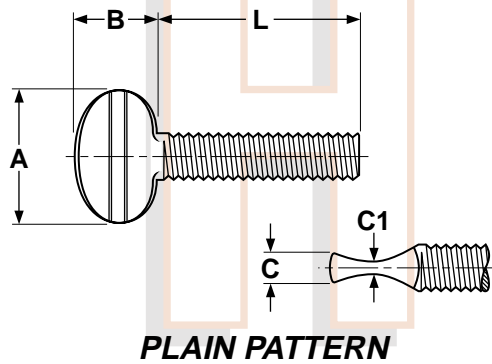

THUMB SCREWS, PLAIN PATTERN (NO SHOULDER)

Nominal Size or Basic Screw Diameter	Threads per Inch	A	B	C	C1	L		
		Head Width	Head Height	Head Thickness	Head Thickness (mid-section)	Practical Screw Lengths		
		Ref	Ref	Ref	Ref	Max	Min	
6	0.138	32	0.41	0.29	0.08	0.03	1.00	0.25
8	0.164	32	0.44	0.30	0.10	0.05	1.00	0.38
10	0.190	24	0.55	0.43	0.12	0.06	2.00	0.38
12	0.216	24	0.47	0.53	0.13	0.06	2.00	0.38
1/4	0.250	20	0.81	0.55	0.16	0.07	2.50	0.50
5/16	0.312	18	0.87	0.67	0.19	0.09	3.00	0.50
3/8	0.375	16	1.02	0.75	0.24	0.11	3.00	0.75
1/2	0.500	13	1.75	1.22	0.39	0.13	3.00	1.00

THUMB SCREWS WITH SHOULDER

Nominal Size or Basic Screw Diameter	Threads per Inch	A	B	C	E	L		
		Head Width	Head Height	Head Thickness	Shoulder Diameter	Practical Screw Lengths		
		Ref	Ref	Ref	Ref	Max	Min	
6	0.138	32	0.28	0.30	0.05	0.24	0.75	0.25
8	0.164	32	0.33	0.39	0.05	0.27	0.75	0.38
10	0.190	24 & 32	0.39	0.49	0.07	0.33	1.00	0.38
12	0.216	24	0.47	0.53	0.13		2.00	0.38
1/4	0.250	20	0.48	0.57	0.10	0.43	1.50	0.50
5/16	0.312	18	0.57	0.73	0.13	0.57	1.50	0.50
3/8	0.375	16	0.71	0.88	0.21	0.71	2.00	0.75

Due to the variation in head dimensions from different manufacturers, thumb screws may not always conform to the listed specifications.

Tolerance on Length	Nominal Screw Length		
	Up to 1 in., Incl.	Over 1 to 2 in., Incl.	Over 2 in.
	±0.03	±0.06	±0.09

Description	A cold headed, one-piece screw with rolled threads and a flattened head designed for manual turning without a driver or wrench. They are available in two varieties--with and without a shoulder under the head. The shoulder flares to a circular shape of a diameter slightly less than the head diameter of the screw.	
Applications/ Advantages	For use in applications where the fastener is frequently adjusted and where tightening torque greater than that achieved with finger pressure is not required. A shoulder-pattern allows the head of the screw to seat flush against the mating surface and helps avoid over-tightening of the fastener which could result in stripped mating threads.	
Material	<i>Steel</i> Commercial quality carbon steel.	<i>Stainless</i> 18-8 Stainless
Tensile Strength	48,000 psi. minimum	-
Plating	See Appendix-A for plating information.	Stainless thumb screws are typically supplied without secondary finishes.